



bioenergy2020+

Production of second generation biofuels based on biomass gasification

DI Gerald Weber
Researcher

Dr. Barbara Rehling
Senior Researcher

Area II-1
Key researcher
Prof. Hermann Hofbauer

Area manager
Dr. Reinhard Rauch

17.09.2015

COMET

Competence Centers for
Excellent Technologies

Bioenergy2020+ and Team of R&D

bioenergy2020+

Bioenergy 2020+ is a Competence Centre funded according to the rules of the COMET program from Austria

Areas of research:

Area I: Biomass Combustion Systems

Area II: *Biomass Gasification Systems*

Area III: Bioconversion & Biogas Systems

Employees: about 60 full time equivalents

Homepage: <http://www.bioenergy2020.eu/>

Area II: Scientific partner



TECHNISCHE
UNIVERSITÄT
WIEN
Vienna University of Technology



Several company partners

Güssing Renewable Energy, Repotec, Mondi,....

The basic concept – “Green Chemistry”

Over 80,000 hours of gasifier operation

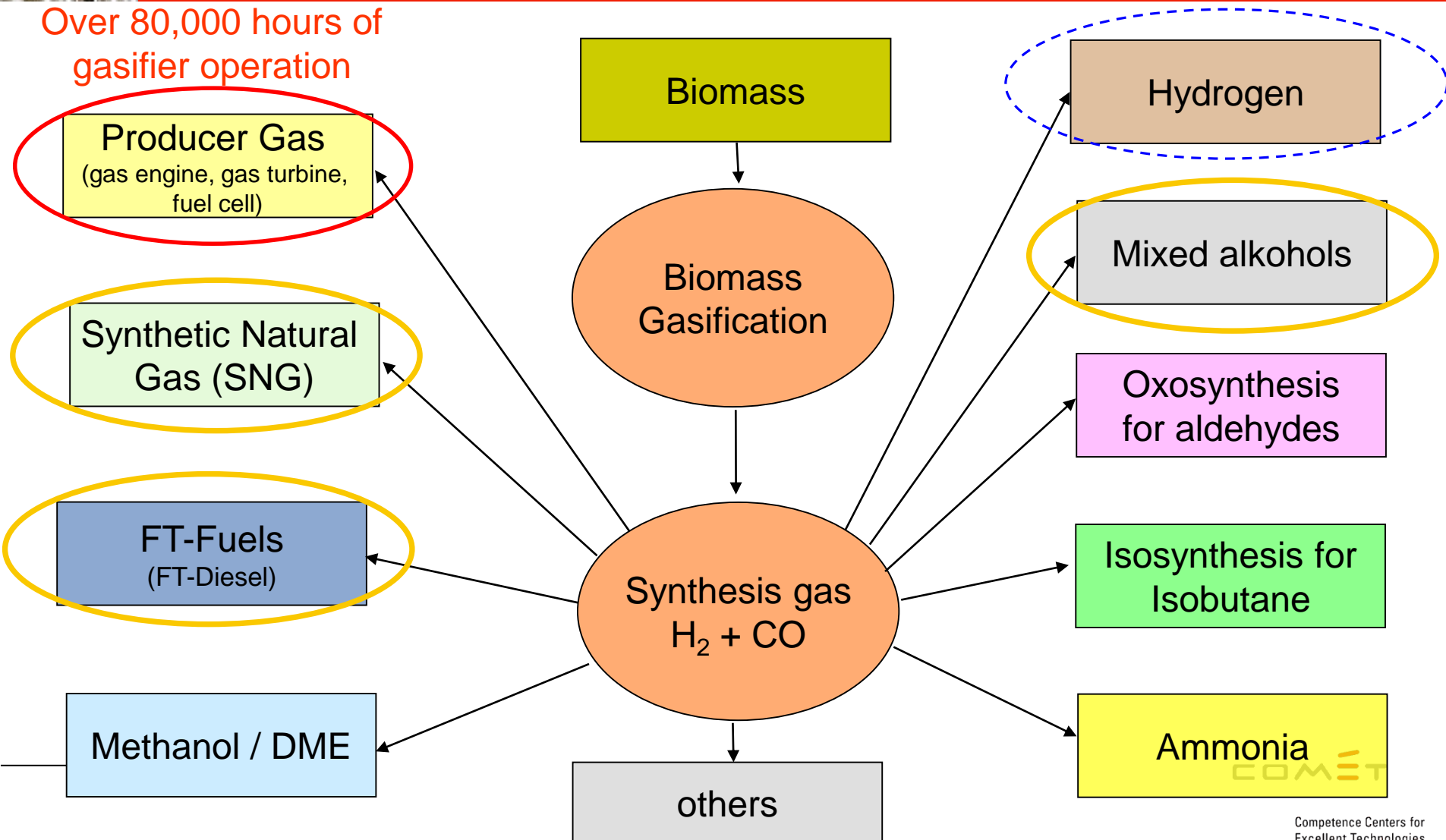

R&D activities at the location Güssing on syngas

8MW steam blown dual fluid gasifier, CHP, Output: $4,5\text{MW}_{\text{th}} + 2\text{MW}_{\text{el}}$

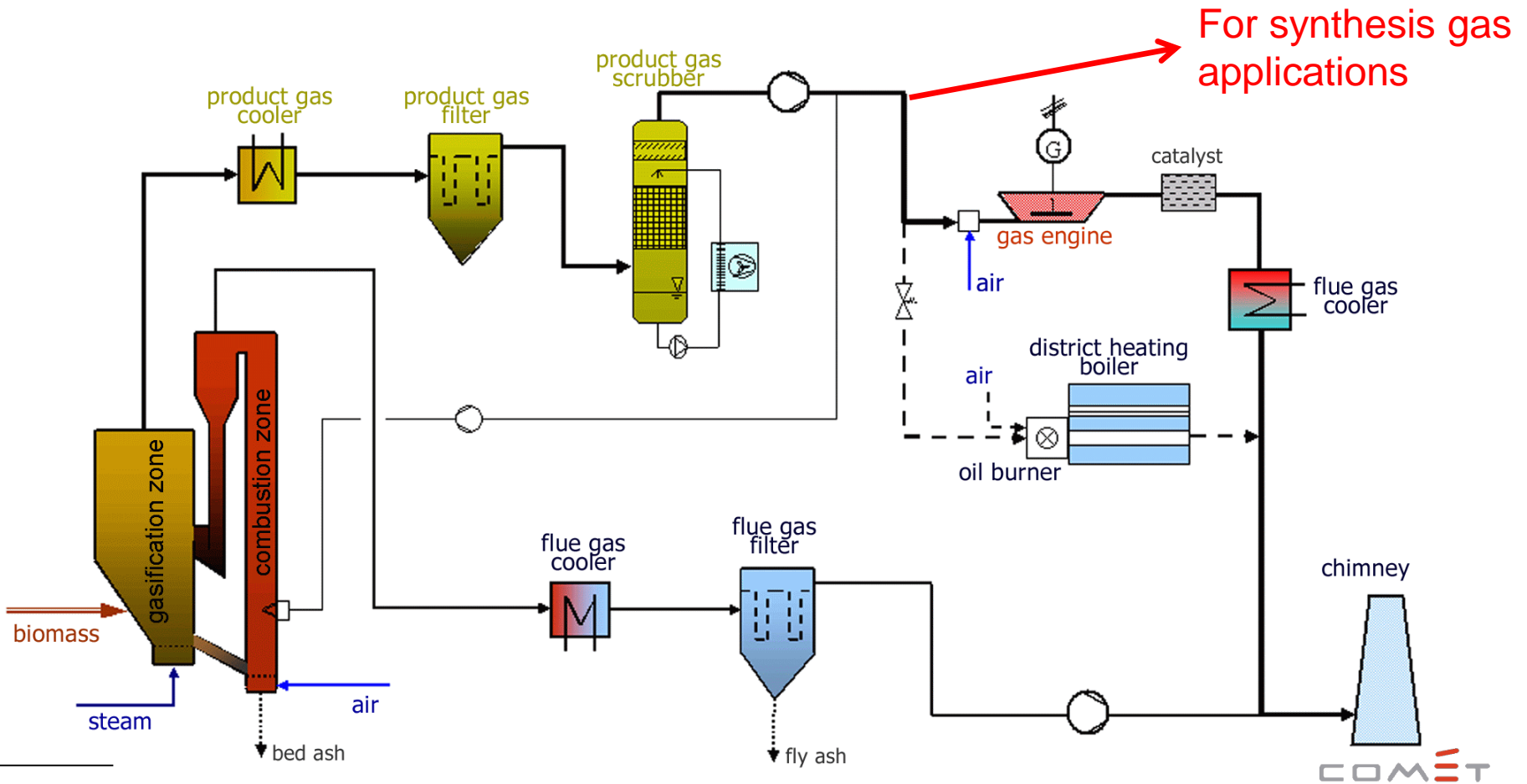



R&D activities at the location Güssing on syngas

- Bio-SNG
- Fischer Tropsch (FT) synthesis
- Mixed alcohols synthesis
- BioH₂ for industry



R&D activities at the location Güssing on syngas

- *Bio-SNG*
- *Fischer Tropsch (FT) synthesis*
- Mixed alcohols synthesis
- BioH₂ for industry

Technology development

Idea – research facilities & tools - pilot plant – demo plant

Lab scale

Pilot + Demo Plant

Industrial Plant

Bio-SNG



FT



Status of technological development

From gasification based CHP to polygeneration plants

Bio-SNG	Güssing, Demonstration scale (1 MW, 2009)
<i>Bio-SNG*</i>	<i>GoBiGas, Industrial scale (20 MW, 2013)</i>
Hydrogen	Güssing, Laboratory scale (1 Nm ³ /h, 2013)
FT	Güssing, Laboratory scale (5-10 kg/day, 2005)
FT	Güssing, Pilot scale (1 barrel/day, 2016)
Mixed alcohols	Güssing, Laboratory scale (2 l/day, 2011)

* BE2020 not involved

Bio-SNG

- 1 MW pilot and demonstration unit for SNG
- Demonstration of the complete process chain from wood to Bio-SNG at a high efficiency
- Fueling of CNG cars with Bio-SNG

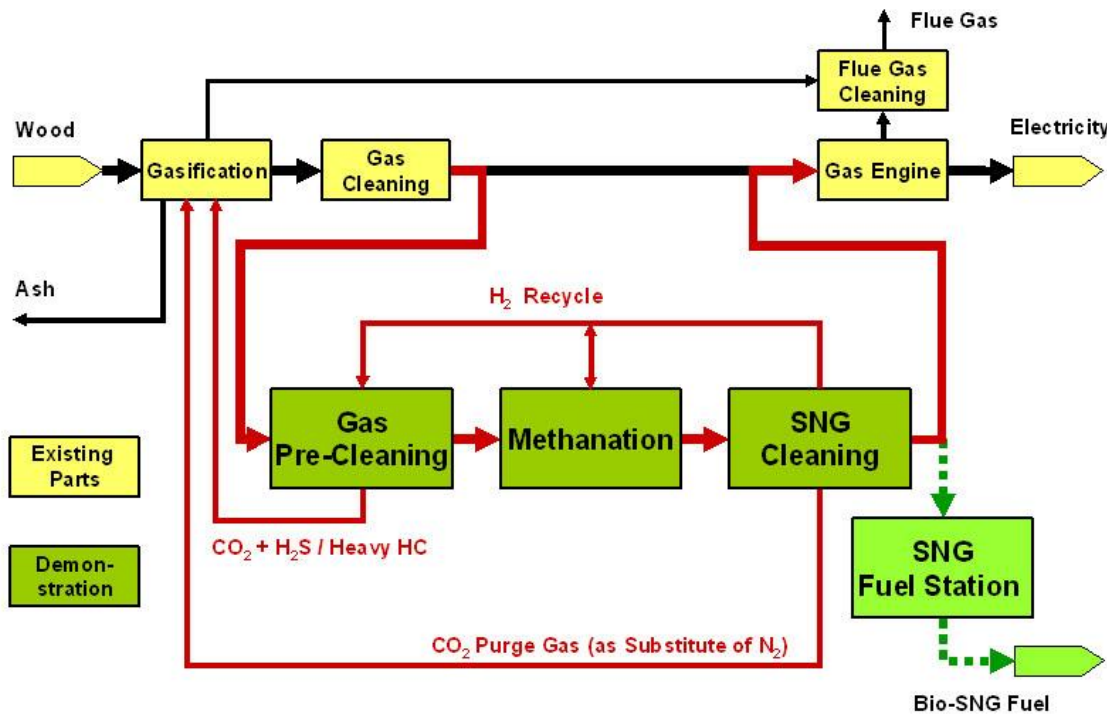

Bio-SNG

- Results were in line with expectations
- CH₄ contents of 96% could be reached
- Quality of produced Bio-SNG exceeded expectations
- Pilot plant was successfully run to design values
 - Required quality for CNG cars fuel
 - Pipeline specifications

	Unit	Germany DVGW Regulation G260	Austria ÖVGW Regulation G31	Bio-SNG
Wobbe Index	[kWh/m ³]	12,8-15,7	13,3-15,7	14,15
Relative density	[-]	0,55-0,75	0,55-0,65	0,56
Higher heating value	[kWh/m ³]	8,4-13,1	10,7-12,8	10,7

Synthetic biofuels (FT- Route)



**Cellulose, Polyose (Hemicellulose)
Lignin**



**i/n- paraffins
(hydrocarbons)**

FT lab scale plant

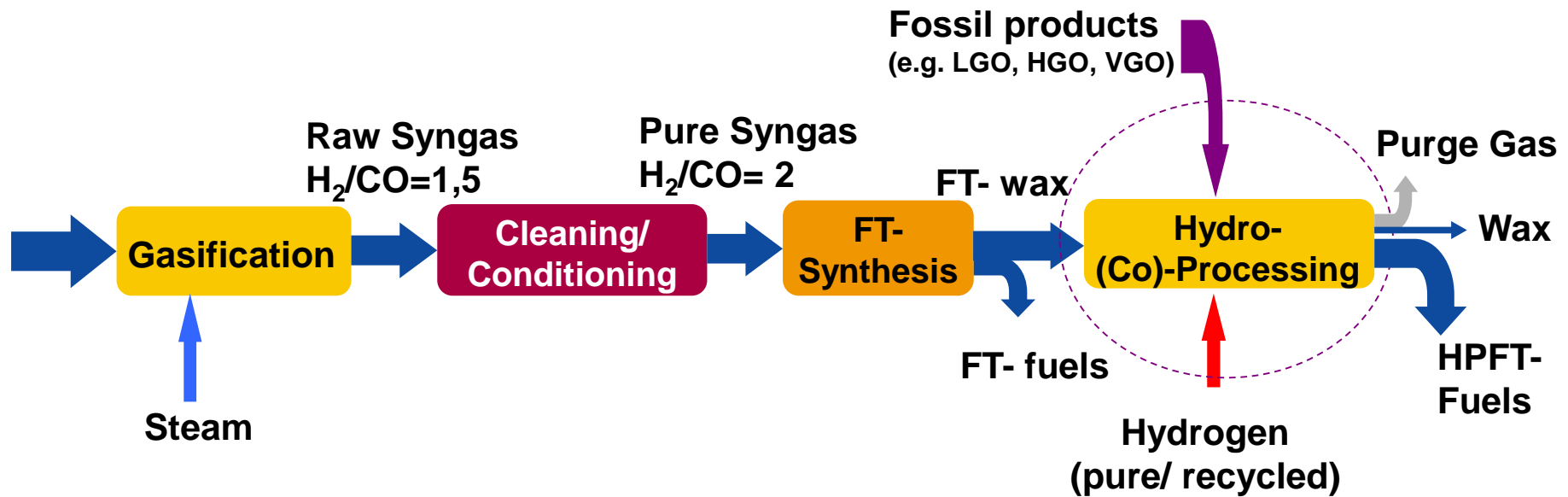

- Fully automatic operation since 2005
- 5-10kg/day of FT raw product
- Slurry reactor, because of excellent heat transfer and easy scaling up
- Gas treatment removes sulphur to below 10ppb
- Cobalt and Iron- based catalysts were tested

Results of experiments with FT synthesis

- 6000 hours of operation with lab scale plant
- FT wax fraction was hydro-processed for enlarging the amount of diesel (HPFT)
- Engine tests with blends of FT/HPFT diesel were carried out successfully
- FT diesel has a high standard of quality
 - 2nd generation biofuel, combustion emits nearly no soot, high cetane number, FT diesel not in competition to food industry like biofuels of 1st generation
 - FT wax can be used in chemical industry
- Upscaling to 1 barrel/day plant is carried at the moment (Start-up of pilot plant is scheduled for middle of 2016)

	FT- Diesel	HPFT- Diesel	CEC- Prüf.
ACN:	>72 $t_d = 2,5$ s	68,5 $t_d = 2,91$ s	>51,8 /
CFPP/CP/FP:	-12/ -9/ - °C	-62/ -60 / -98°C	-18/ -5 °C

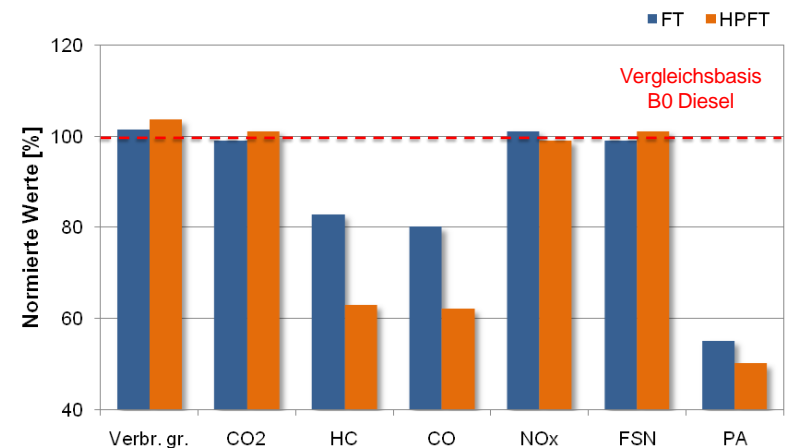
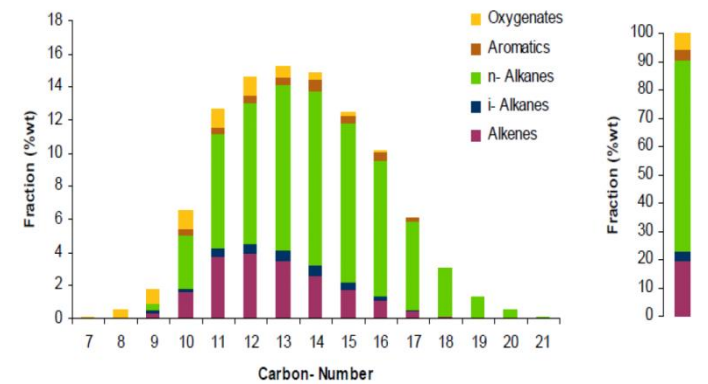

Economic considerations

- Complex technology -> high investment costs (~1-1.5 Mio EUR per MW gasification power, depending on used technology and scale)
- Efficiency from input material to transportation fuel is about 40-70%, so much worse than refinery (>90%), but much better than electricity (~20-30%) from biomass, total efficiency (fuel + heat + electricity) > 80%
- Fuel costs have the highest influence on production costs (>50%)
- Problems: high investment costs + no security of supply of biomass (in Europe)

Product	Production costs	Production costs €/GJ
FT-Diesel	0,6-1,0 €/l	15-30
Bio-SNG	0,7-0,9 €/Nm ³	19-25
Methanol	0,2-0,4 €/l	10-15
Biodiesel	0,7-0,8 €/l	23-27
Bioethanol	0,5-0,8 €/l	25-33



Conclusion

- Interest for the production of transportation fuels (trucks, jet) are rising caused by security of supply and climate change issue. Main interests are focus on the use of advanced biofuels (second generation)
- Several different gasification technologies are used for production of synthesis gas from biomass, only DFB steam gasification technology in commercial operation (for CHP, not for synthesis gas)
- Research topic of BE2020 in the field of syngas utilization: Bio-SNG, FT (Diesel), MAS (Alcohols), Bio-H₂
 - Main advantage of SNG is the high conversion efficiency of up to 70%, H₂ is in the area of 60%, FT between 40 to 45%, MAS around 40%
 - Future research activities are more focused on FT => upscaling to pilot scale (1 Barrel/day in 2016)
- **On the long term there is no alternative to advanced biofuels. Hydrocarbons will be the main fuel for the next decades**

Thank you for your attention!

